

Main applications

- Climatic chambers and test benches
- Ovens that require a setpoint that changes over time
- Sterilisers, Autoclaves, Dryers, Moulding Equipment
- Chemical and pharmaceutical industries
- Food processing plants
- Siderurgy industry
- Furnaces for ceramics and bricks
- Painting cabinets



Main features

- Thermocouple, resistance thermometer and linear inputs with configurable scales and characterisation
- Remote setpoint, valve position or load current sensing input (optional)
- 8 configurable optoisolated digital inputs (optional)
- 8 configurable optoisolated outputs that may be programmed with time (optional)
- Double independent PID outputs (Heat/Cool) 10 sets of PID tuning parameters to select from for each program step
- Configurable isolated retransmission output
- 2...10 configurable alarms
- Expansion up to 16 relay outputs (optional) (with 2 MD81 units)
- Serial line: optoisolated 4-wire configurable.
Protocol:
GEFRAN CENCAL or MODBUS

GENERAL

Microprocessor setpoint programmer and controller in 48x96 / 96x96mm format (1/8 DIN - 1/4 DIN).

Manufactured using SMT, the 3500 provides a complete operator interface with IP54 level of protection (IP65 with faceplate cover).

The faceplate has a membrane keypad with 6 keys, a backlit LCD display that is available also with large dimensions (model 4500) that displays the process variable, setpoint, bargraphs of the percentage output power and the deviation and indication of the alarm and controller states.

The main input for the control variable is universal and gives the possibility to connect a wide range of sensors such as thermocouples, resistance thermometers or mV signals even with custom linearisation.

A second optional auxiliary analogue input is available for remote setpoint linear signal, potentiometer valve position feedback or input from a current transformer.

With a digital input it is possible to select between two preset setpoints or switch between local and remote setpoint.

With three isolated digital inputs, it is possible to supply a start, stop and reset signal.

The model 4500 offers the possibility of a further eight isolated programmable digital inputs for enabling and stepping the programme. The instrument has up to four outputs, each one factory configured, according to the order code, as relay, isolated logic, isolated analogue or interface for MD81 expansion unit output.

The output functions are configurable from the faceplate.

Apart from the control outputs, that can be heat-cool with independent PID, and the alarm outputs, outputs can be dedicated to the open/close control of a motorised valve (with or without position feedback potentiometer), retransmission signal of the measured variable, the setpoint, the deviation or the control of the MD8 expansion unit for an extra 8 alarm or programmable event outputs.

The model 4500 gives the possibility of an extra eight isolated digital outputs freely programmable for each step of the programme..

The 3500/4500 series programmer-controllers can use up to 100 steps (100 ramps and 100 holds), grouped in 50 different programmes.

The programmer can have a cyclic function, a time base configurable from seconds to days, software alarms for the control of the response of the controlled system and four different modes of restart after a power out.

The serial communication option can be for Current Loop, RS232 or RS422/485, with selectable CENCAL or MODBUS protocol, and it is possible to read and write any of the instrument's parameters. The programming procedure is simplified by the menu guide structure with different configuration levels for a rapid and easy access to the data.

TECHNICAL DATA

INPUTS

Accuracy 0,1% f.s. \pm 1 digit
Sampling time 120msec

TC- Thermocouple

J (Fe-CuNi) 0...1000°C / 32...1832°F
K (NiCr-Ni) 0...1300°C / 32...2372°F
R (Pt13Rh-Pt) 0...1750°C / 32...3182°F
S (Pt10Rh-Pt) 0...1750°C / 32...3182°F
T (Cu-CuNi) -100...400°C / -148...752°F
B (Pt30Rh-Pt6Rh) (*) 50...1800°C / 122...3272°F
E (NiCr-CuNi) -100...750°C / -148...1382°F
N (NiCr-Si-NiSi) 0...1300°C / 32...2372°F
Ni-Ni18Mo (Ni-Ni18Mo)
 0...1100°C / 32...2012°F

(*) for type B thermocouples, the class of accuracy is valid for temperatures above 500°C.

RTD 2/3-wires

Pt100 -200...600°C / -328...1112°F

DC - Linear

0...50mV, 10...50mV

External shunts are used for voltage ranges 0...10V and current ranges of 0...20mA and 4...20mA.
Custom 32 segment characterisation.

Auxiliary inputs

Isolated 1500V

For remote setpoint:

0...10V - Ri = 100KΩ

0...20mA - Ri = 50Ω

4...20mA - Ri = 50Ω

For potentiometer:

0...1V - Ri > 10MΩ (for use with a potentiometer in the range 100Ω to 20KΩ)

For current transformer:

0...5Aac, 50/60Hz - Ri = 20mΩ

Digital

Isolated 1500V

3 isolated control inputs:

Start (IN1), Stop (IN2), Reset (IN3)

- NPN 12V/3,5mA

- PNP 24V/6mA (12V/2mA)

8 programmable inputs

- NPN 12V/5mA

- PNP 24V/4mA

- PNP 12V/2,5mA

OUTPUTS

The functions programmable from the faceplate keys:

- Heat main
- Cool main
- Repetition of:

programmer setpoint, input, remote setpoint (secondary input), controller setpoint, deviation (setpoint-measured value), deviation (measured value-setpoint)

- Alarm 1 and 2
- Open/Close for motorised valve

Continuous

isolated 1500V

0...10V max 20mA

0...20, 4...20mA load max 500Ω

Resolution 4000 steps, max. update time 80msec.

Relay

With rating 5A/250Vac (with resistive load). Spark suppression on the NO contact.

Logic

Voltage output for SSRs.

23Vdc, Rout = 470Ω (20mA, max. 12V).

MD81

Interface output for MD81 unit.

The functions attributed to each module are programmable from the faceplate keys:

8 event outputs (1...8) of the programmer

8 event outputs (9...16) of the programmer

8 intercept outputs (alarms 3...10)

Digital

Isolated 1500V

8 isolated programmer outputs configured by jumpers:

SOURCE 12V (max. 40mA total)

shortcircuit protection

SINK external 3...30V (max 33V), 50mA

for each output

Ri = 100Ω

Max. reverse voltage: -50V

SERIAL LINE

Optoisolated 4-wires

Passive Current Loop (1200 baud) or

RS422/485, RS232 (1200/2400/4800/

9600 baud).

Protocol: GEFRA CENCAL or MODBUS

POWER SUPPLY

100...240Vac/dc ±10%, 50/60Hz;

12VA max (3500), 15VA max (4500)

Protection by internal fuse not serviceable by the user.

AMBIENT CONDITIONS

Working temperature: 0...50°C

Storage temperature: -20...70°C

Humidity: 20...85%Ur non condensing

CONTROLLER

On/Off, P, PD, PI, PID type control with independent adjustable parameters for the two Heat and Cool terms.

The main adjustable parameters are:

- Cooling setpoint relative to the heating setpoint ±25% f.s.
- Manual reset or deviation correction factor ±999 scale digits
- Offset of the main input ±999 scale digits
- Offset of the secondary input ±999 scale digits
- Digital filter on main input value: 0,1...20,0 sec
- Heating power supply (0...100%) or for Cooling (0...-100%)
- Antireset windup or limitation band of the integral action 0...9999 scale digits
- Feed Forward in the range ±100%
- Proportional band 0,0...999,9% f.s.
- Integrale time 0,00...99,99 min
- Derivative time 0,00...9,99 min
- Max. limit of power 0...100%

The main control and support functions are:

- Soft-start: gradual increase of the power of the main output, following the power up of the instrument, in the time: 0,0...100,0 min
- Self-Tuning; Auto-Tuning
- LBA: with the possibility to set a time (0,0...20,0 min) and power (0,0...100,0%) (time = 0 disables the action)
- H: Holdback or max. control tolerance about the setpoint alarm 1...9999 scale digits (= 0 disables the action)
- HB: Heat Break or alarm for interrupted load with reference to the ammeter input.

PROGRAMMER

Accuracy of the time base: better than ± 4 sec every 10 hours (< 0,01% dof a hold time or ramp time of a program step).

The programmer function allows a program made of segments or steps, each one consisting of a ramp or a hold, to be

FACEPLATE DESCRIPTION

- A** - Indication of process variable, h. digits 10mm (3500) and 20mm (4500)
- B** - Indication of setpoint, h. digits 7mm (3500) and 14mm (4500)
- C** - Deviation display
- D** - Main output indicator
- E** - Function key
- F - G** - Lower/Raise keys
- H** - Data key
- I** - Man/Auto key
- L** - Local/Remote key
- M** - Status indicator

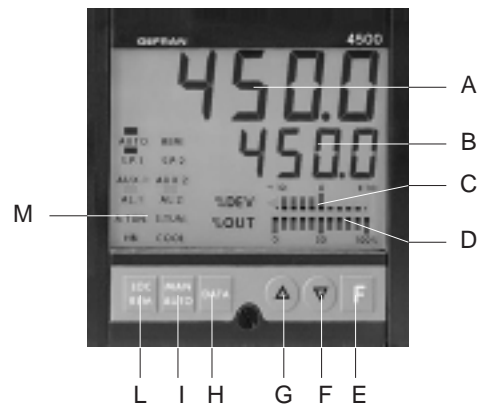
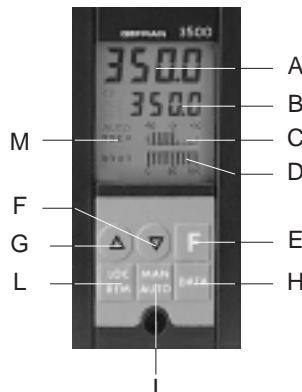

LCD backlit display
IP54 faceplate protection (IP65 available)

followed.

There are a total of 100 steps available that can be used in a max. 50 programs. Each step is a combination of different information:

- Setpoint
- Programmable ramp time 99days 23hrs 59min. 59sec. or programmable ramp in 0 scale digits 999,9 min.
- Hold time of the programmable setpoint in dd/hh/mm/ss.
- Tolerance band (H alarm) that may be entered as 0...9999 scale digits.
- Number of the PID parameter set (= 0 to maintain the previous set).
- Code for the combination of the 1...8

digital outputs

- Code for the combination of the 9...16 digital outputs
- Code for the combination of the 8 test inputs to be ON.
- Code for the combination of the 8 test inputs to be OFF.

ALARMS

- 2 + 8 intercepts may be entered in absolute value, deviation or symmetrical deviation with respect to the setpoint with high or low alarm action.
- The faceplate keys can be used to configure the LBA, HB and H alarms. Limits can be entered within the configu-

red scale.

The non-repetitive response time is less than max. 80msec.

WEIGHT

600g (3500), 850g (4500)

DIMENSIONS AND CUT-OUT

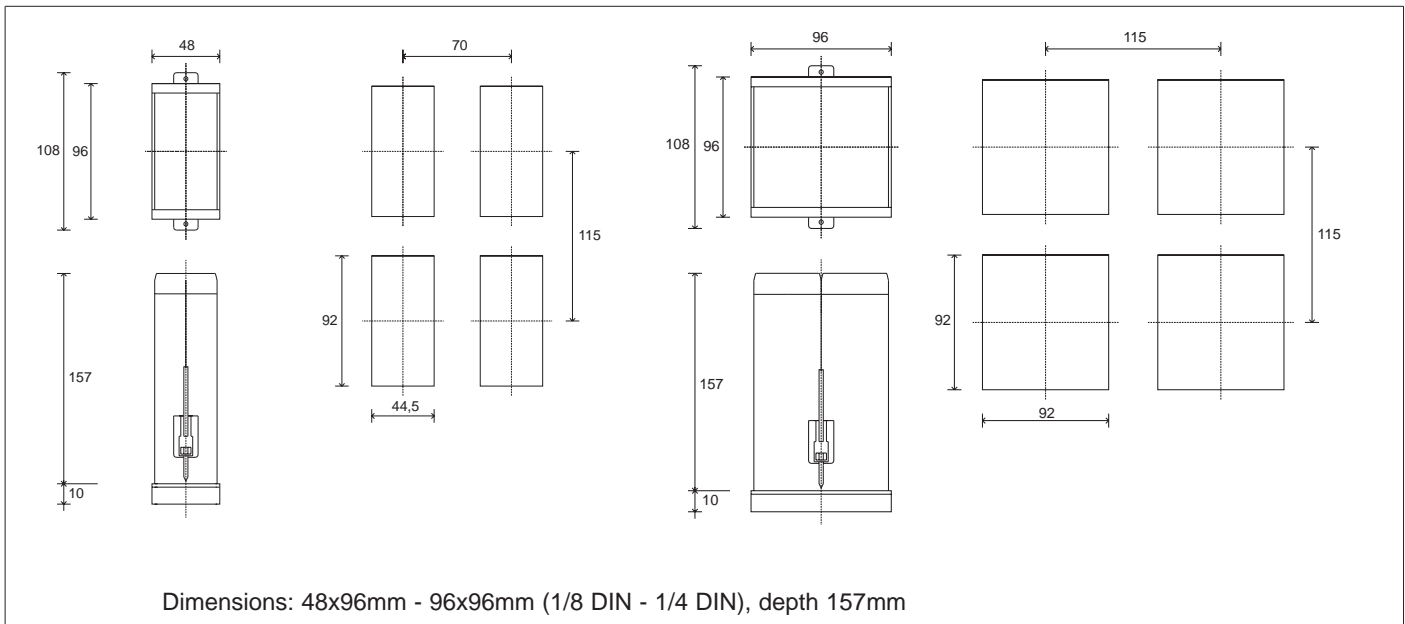

CONNECTION DIAGRAM

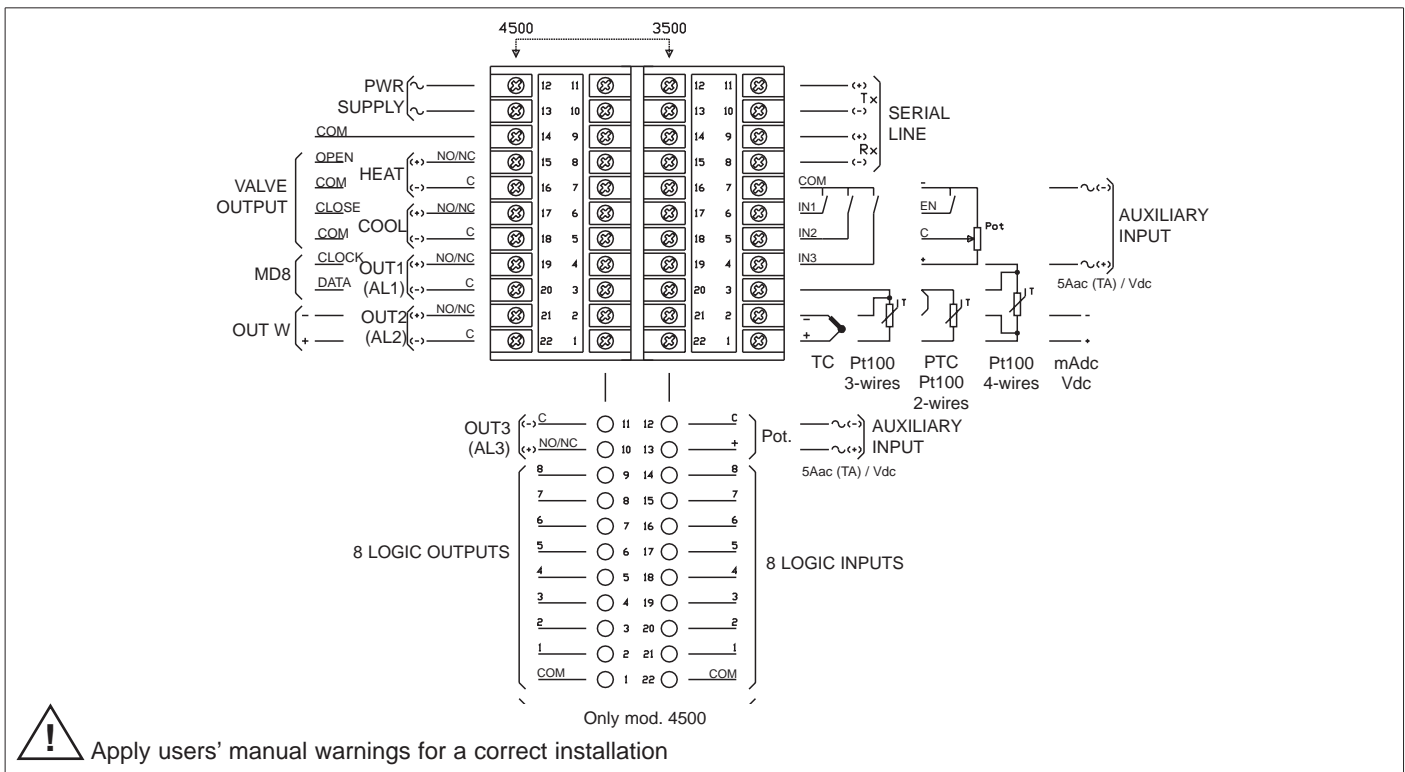

ORDER CODE

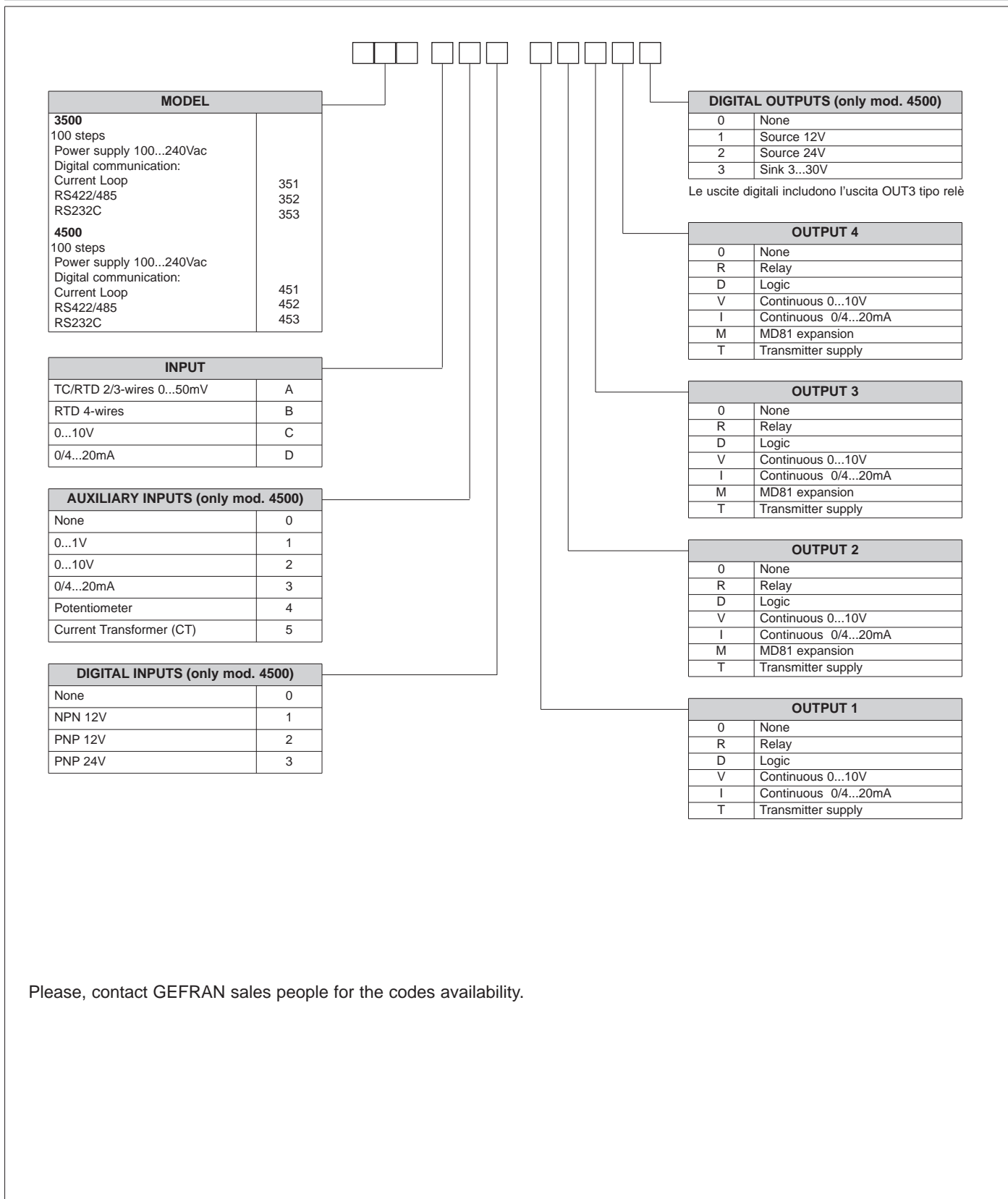

Please, contact GEFRA sales people for the codes availability.

GEFRAN spa reserves the right to make any kind of design or functional modification at any moment without prior notice



The instrument conforms to the European Directives 2004/108/CE and 2006/95/CE with reference to the generic standards: **EN 61000-6-2** (immunity in industrial environment) **EN 61000-6-3** (emission in residential environment) - **EN 61010-1** (safety)

GEFRAN

GEFRAN spa via Sebina, 74 - 25050 Provaglio d'Iseo (BS)
Tel. 03098881 - fax 0309839063 - Internet: <http://www.gefran.com>

DTS_3500-4500_0409_ENG